

Quattro offen

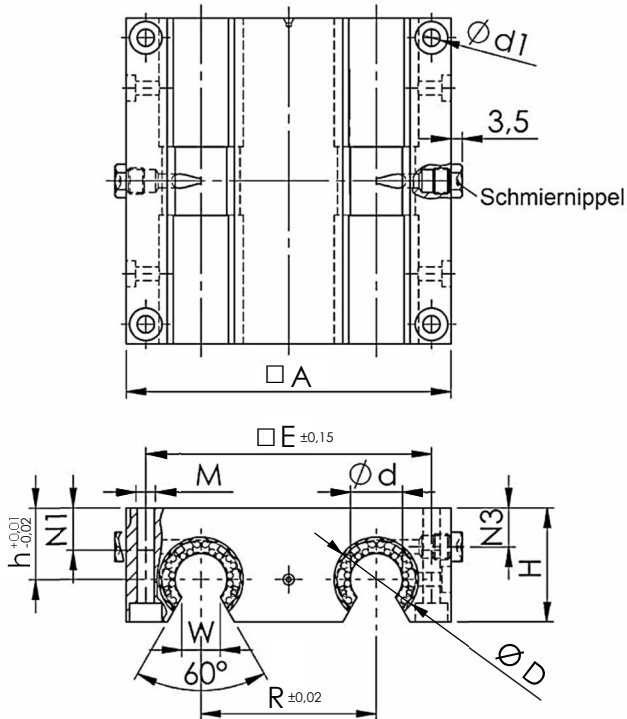

Teile-Nr.	Abmessungen in mm												Gewicht kg
	d	D	H	h	A	E	N1	N3	d1	R	W	M	
KQSO-12	12	22	30	18	85	75	13	13	5,3	42	7,0	M6	0,39
KQSO-16	16	26	35	22	100	88	13	15	5,3	54	9,4	M6	0,63
KQSO-20	20	32	42	25	130	115	18	13	6,8	72	10,2	M8	1,30
KQSO-25	25	40	51	30	160	140	22	24	9,0	88	12,9	M10	2,30
KQSO-30	30	47	60	35	180	158	26	27	10,3	96	13,9	M12	3,40
KQSO-40	40	62	77	45	230	202	34	35	13,5	122	18,2	M16	6,85
KQSO-50	50	75	93	55	280	250	34	40	13,5	152	33,0	M16	12,55

- Lieferung ohne Linearkugellager
- Gewichtsangabe ohne Linearkugellager
- Befestigung des Lagers im Gehäuse erfolgt über Axial-Radialfixierschraube
- Befestigungsschrauben DIN 912 - 8.8, Federring DIN 7980
- Sonderbauform auf Anfrage