

Lineargehäuse KTGO87

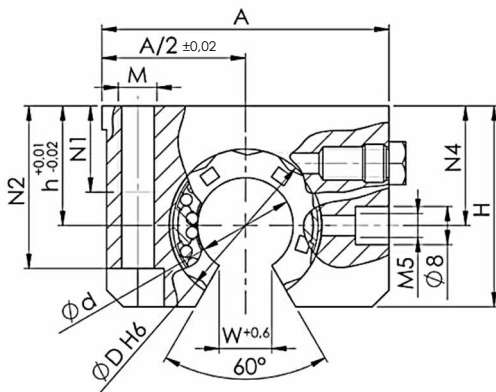

Tandem offen

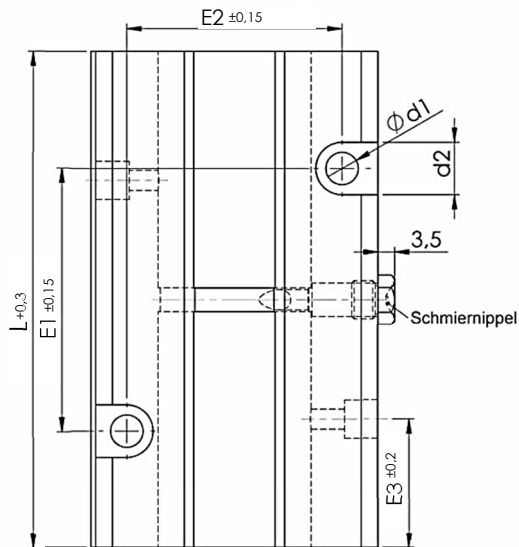

Teile -Nr.	Abmessungen in mm																Gewicht kg
	d	D	H	h	A	L	N1	N2	N4	E1	E2	E3	d1	d2	M	W	
KTGO87-12	12	22	30	18	43	76	13	25	16,65	40	30	19,5	5,20	10	M6	7,0	0,17
KTGO87-16	16	26	35	22	53	84	13	30	22,00	45	36	21,5	5,20	10	M6	9,4	0,28
KTGO87-20	20	32	42	25	60	104	18	34	25,00	55	45	27,0	6,80	11	M8	10,2	0,44
KTGO87-25	25	40	51	30	78	130	22	40	31,50	70	54	33,5	8,60	15	M10	12,9	0,90
KTGO87-30	30	47	60	35	87	152	26	48	33,00	85	62	39,5	10,30	18	M12	14,4	1,30
KTGO87-40	40	62	77	45	108	176	34	60	43,50	100	80	45,0	14,25	20	M16	18,2	2,30
KTGO87-50	50	75	88	50	132	224	34	49	47,50	125	100	56,5	14,25	20	M16	33,0	3,85

- Lieferung ohne Linearkugellager
- Gewichtsangabe ohne Linearkugellager
- Befestigung des Lagers im Gehäuse erfolgt über Axial-Radialfixierschraube
- Befestigungsschrauben DIN 912 - 8,8, Federring DIN 7980