

Lineargehäuse KGOE38

Einzel offen
Radialluft einstellbar

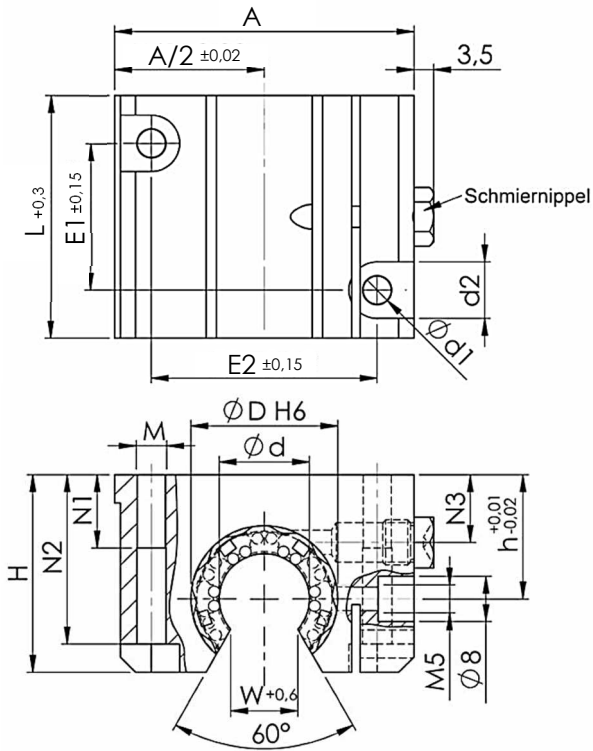

Teile-Nr.	Abmessungen in mm															Gewicht
	d	D	H	A	L	N1	N2	N3	h	E1	E2	d1	d2	W	M	
KGOE38-12	12	22	28	43	39	11	23,5	8	18	23	32	4,20	8	7,0	M5	0,08
KGOE38-16	16	26	35	53	43	13	30,0	12	22	26	40	5,20	10	9,4	M6	0,14
KGOE38-20	20	32	42	60	54	18	34,0	13	25	32	45	6,80	11	10,2	M8	0,21
KGOE38-25	25	40	51	78	67	22	40,0	15	30	40	60	8,60	15	12,5	M10	0,44
KGOE38-30	30	47	60	87	79	22	48,0	16	35	45	68	8,60	15	13,9	M10	0,67
KGOE38-40	40	62	77	108	91	26	60,0	20	45	58	86	10,30	18	18,0	M12	1,20
KGOE38-50	50	75	88	132	113	34	49,0	20	50	50	108	14,25	20	33,0	M16	1,90
KGOE38-60	60	90	118	178	142	40	100,0	–	69	90	130	17,50	26	43,0	M20	6,00
KGOE38-80	80	120	158	232	185	48	136,0	–	93	110	170	22,00	33	61,0	M24	12,90

- Lieferung ohne Linearkugellager
- Gewichtsangabe ohne Linearkugellager
- Befestigung des Lagers im Gehäuse erfolgt über Axial-Radialfixierschraube
- Befestigungsschrauben DIN 912 - 8.8, Federring DIN 7980