

# Lineargehäuse KALGS

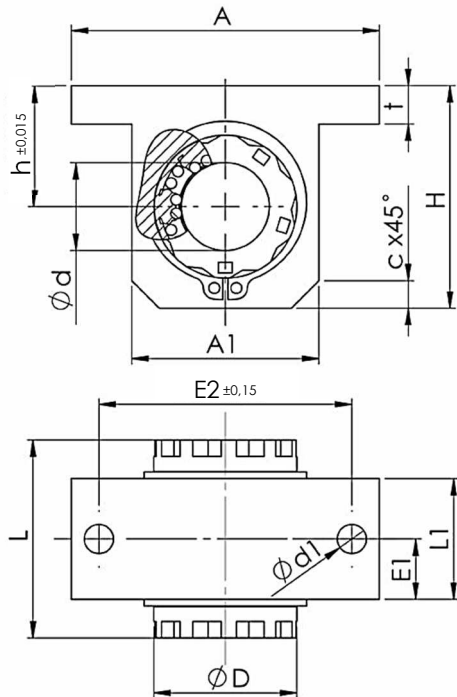

Standard geschlossen



Teile-Nr.	Abmessungen in mm													Gewicht
	KALGS	d	D	H	h	A	A1	E1	E2	L	L1	d1	c	
KALGS-12	12	22	35,0	18	52	30	10	42	32	20	5,3	5	6	0,04
KALGS-16	16	26	40,5	22	56	34	11	46	36	22	5,3	5	7	0,06
KALGS-20	20	32	48,0	25	70	40	14	58	45	28	6,4	5	8	0,10
KALGS-25	25	40	58,0	30	80	50	20	68	58	40	6,4	6	10	0,20
KALGS-30	30	47	67,0	35	88	58	24	76	68	48	6,4	6	10	0,31
KALGS-40	40	62	85,0	45	108	74	28	94	80	56	8,4	8	12	0,54
KALGS-50	50	75	100,0	50	135	96	36	116	100	72	10,5	8	12	1,05

- Lieferung ohne Linearkugellager
- Gewichtsangabe ohne Linearkugellager
- Befestigung des Lagers im Gehäuse erfolgt über Sicherungsringe nach DIN 471
- Befestigungsschrauben DIN 912 - 8.8, Federring DIN 7980