

## U-Profil Standard nb

warmgewalzt

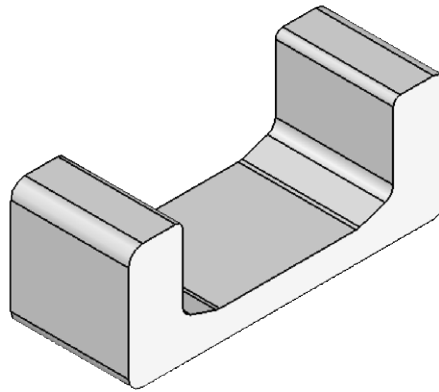

- Oberflächenbehandlungen  
(grundieren, verzinken, usw. ..)
- Bearbeitungen  
(bohren, fräsen, Gewinde schneiden  
nach Kundenzeichnungen bzw. Kundenangaben)

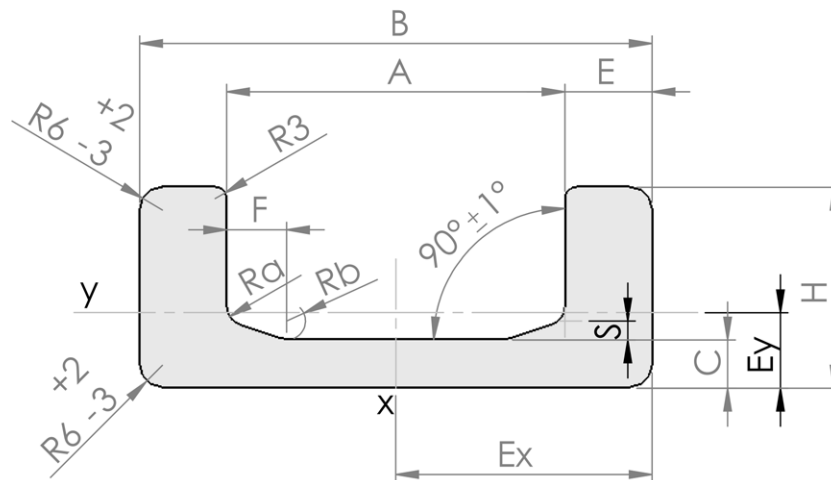

U-Profil Standard...	A	B	C ±0.5	H ±0.8	E ±0.5	F	Ra	Rb	S	Ex	Ey	Gewicht in kg/m	Wx in cm <sup>3</sup>	Wy in cm <sup>3</sup>	Ix in cm <sup>4</sup>	Iy in cm <sup>4</sup>
HT0-nb	62,5 <sup>+1</sup>	86,5	7,0	36,0	12,0	15	4	4	3	43,25	12,87	10,50	32,00	6,00	137,00	15,00
HT1-nb	70,8 <sup>±0.5</sup>	103,2	7,7	40,0	16,2	15	5	5	3	51,60	14,99	14,78	53,00	11,00	273,00	27,00
HT2-nb	78,7 <sup>±0.5</sup>	121,3	10,8	41,0	21,3	15	5	5	5	60,65	15,43	20,93	81,00	15,43	493,58	37,92
HT3-nb	89,4 <sup>±0.5</sup>	135,4	12,7	53,0	23,0	15	5	5	5	67,70	19,90	28,60	127,80	27,03	865,23	89,47
HT4-nb	108,4 <sup>±0.5</sup>	157,2	14,0	61,2	24,4	15	5	5	5	78,60	22,49	35,90	190,12	39,00	1494,32	150,98
HT5-nb	123,8 <sup>±0.5</sup>	175,0	16,2	66,2	25,6	15	5	5	5	87,50	19,41	42,90	249,75	48,42	2185,32	205,84
HT6-nb	150,1 <sup>±0.5</sup>	201,5	19,4	71,2	25,7	20	6	6	5	100,75	20,01	52,25	339,76	57,15	3423,08	269,52